

EQUIPO DE EMERGENCIA



Descripción

Equipo de emergencia LED, doble, para uso interior, ideal para oficinas, bar, restaurant, entre otros.

Descripción Técnica

Potencia: 2*1,2W

Color de luz: 5900K

Tiempo de descarga: 3 Hrs

Tiempo de carga: 15 – 20 Hrs.

Voltaje: 110/220V

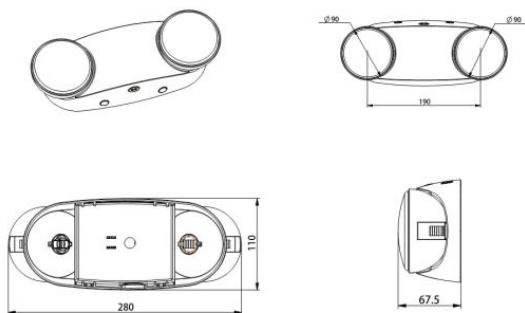

EQUIPO DE EMERGENCIA

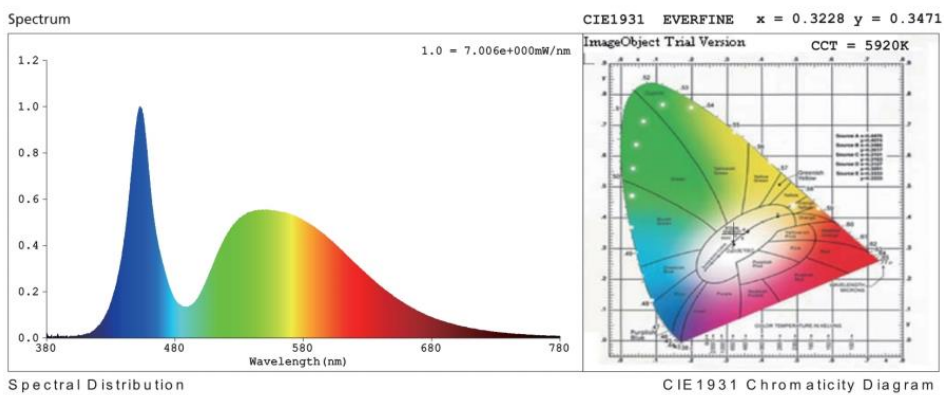

Colorimetric Parameters

Chromaticity Coordinate: $x = 0.3228$ $y = 0.3471$ / $u' = 0.1981$ $v' = 0.4792$ ($duv=7.42e-03$)

CCT= 5920K Prcp WL: Ld=510.2nm Purity=3.3%

Peak WL: Lp=453nm FWHM: =21.7nm Ratio:R=12.5% G=83.5% B=4.0%

Render Index: Ra = 73.1

R1 =69 R2 =78 R3 =82 R4 =72 R5 =70 R6 =69 R7 =84

R8 =59 R9 =-29 R10=46 R11=67 R12=39 R13=71 R14=90 R15=65

Photometric & Radiometric Parameters

Flux = 229.87 lm Eff. : 0.00 lm/W Fe = 697.95 mW